



Logis-Tech Tokyo 2024

DATE Sep. 10 (Tue.) ~ Sep. 13 (Fri.)

AM10:00~PM5:00

VENUE Tokyo Big Sight (EAST HALL1-8)

Package Displays and Rental Items

Application due: Aug.7.2024.

【Apply to/ Inquiry】

KOGEISHA CO.,LTD.

6-17-5 Hongo, Bunkyo-Ku, Tokyo 113-0033

Tel : 03-5801-0792 Fax : 03-5801-0795

E-mail : expo@kogeisha.co.jp

Schedule of Exhibition

Application of booth plan

Applied Standard Booth
(Space Only)

Applied Booth Decoration Plan

- 1 booth
- 2 booths
- 3 booths

※ Separate quotation
for 4 booths or above

Is the constructor decided?

YES

NO

1 booth~3 booths

Apply for
Booth Decoration Plan

4 booths or above

Email to
expo@kogeisha.co.jp
For further enquiries

What is the Booth Decoration Display

The term "Booth Decoration display" refers to a set of booth decorations, rental equipment, electrical work, etc. necessary for booth decoration and exhibition without the need for in-house construction and decoration. This exhibition uses the Octanorm system, a reusable system of leasing components. The basic plan includes a parapet, company name sign, carpet, reception set, and lighting. Optional plans are also available that add display stands, shelves, and display lighting. This brochure shows a typical assembly example.

Standard booth specifications (1 booth)

If decoration Plan is NOT ordered

Booth specs to be received on move-in day

※For corner booths, side panels will not be attached to the aisle side.

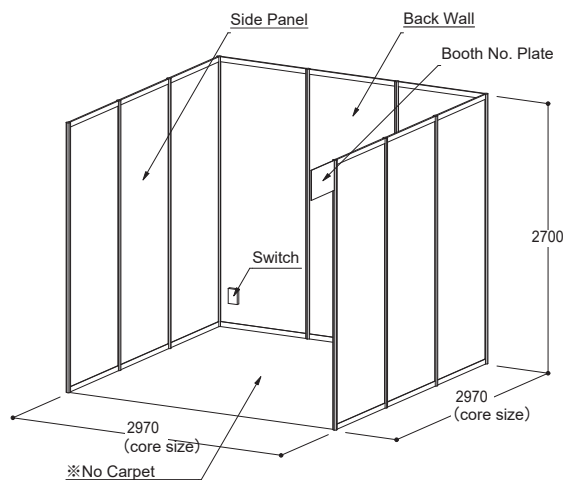

Booth Decoration Plan (1 booth)

If you apply for a Booth Decoration Plan

Booth specifications to be received on move-in day

※Corner booths will not have side panels on the aisle side, but will have a parapet (without a company name sign).

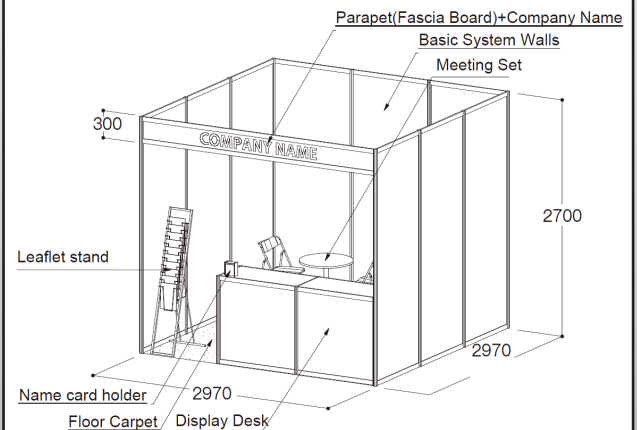

Basic dimensions of system components

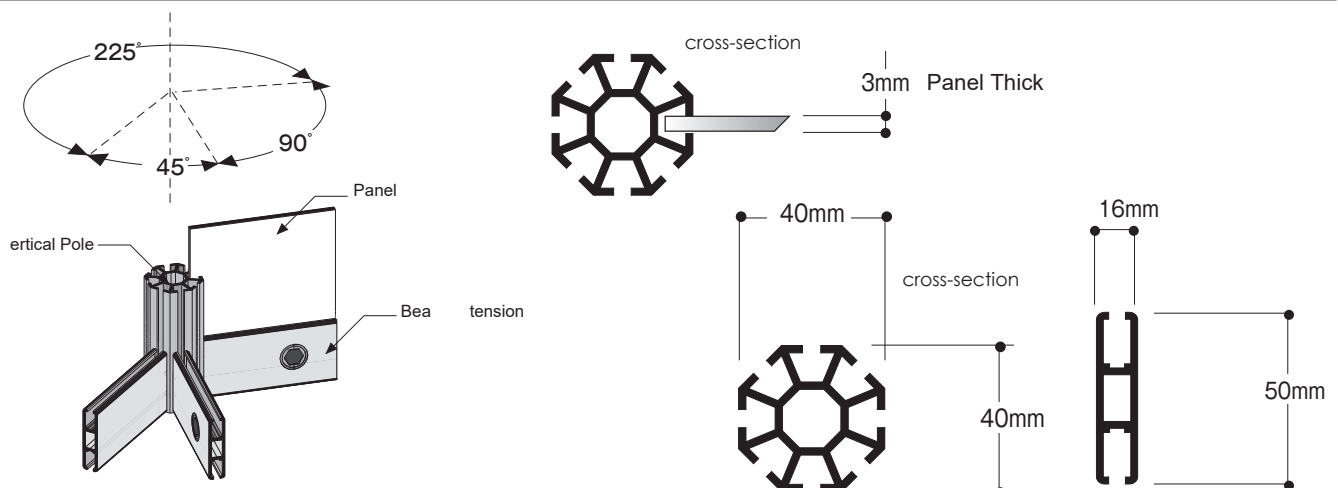

Information of Booth Decoration Plan

Booth Decoration Plan 1 Booth

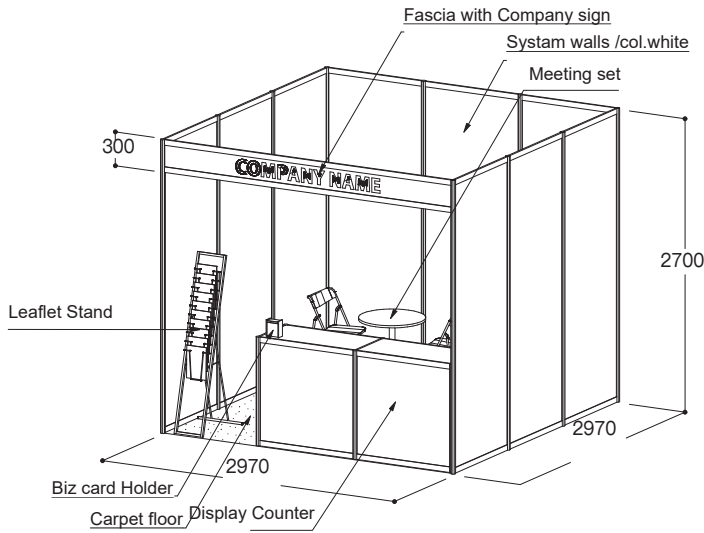

- Display Counter W1000×D500×H1000 2units
- Leaflet Stand (A4 12row) 1unit
- Round Table (600mm) 1unit
- Folding Chair..... 2units

※Corner booths will not have side panels on the aisle side, but will have a parapet (without a company name sign).

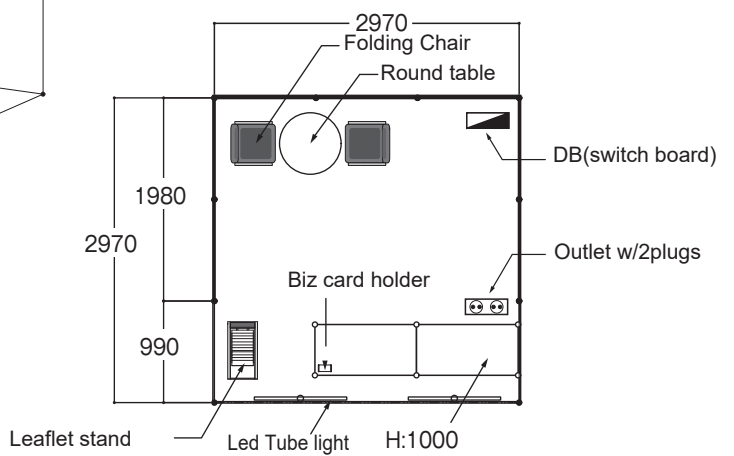

◆JPY. 157,300-(tax included.)

Booth Decoration Plan 2 Booths

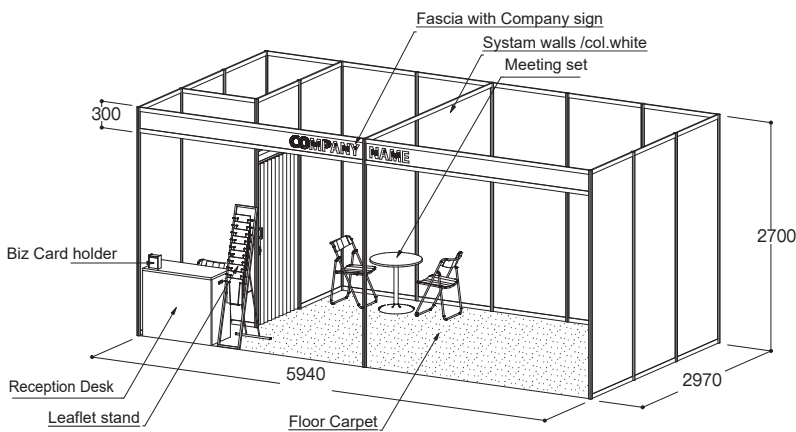

- Reception Counter W900×D500×H900 1unit
- Leaflet Stand (A4 12row) 1unit
- Round Table (600mm) 1unit
- Folding Chair..... 3units

※Corner booths will not have side panels on the aisle side, but will have a parapet (without a company name sign).

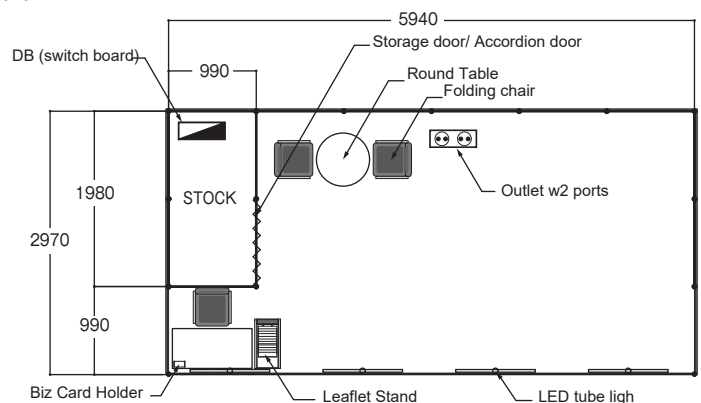

◆JPY.23,850-(tax included.)

Booth Decoration Plan 3 Booths

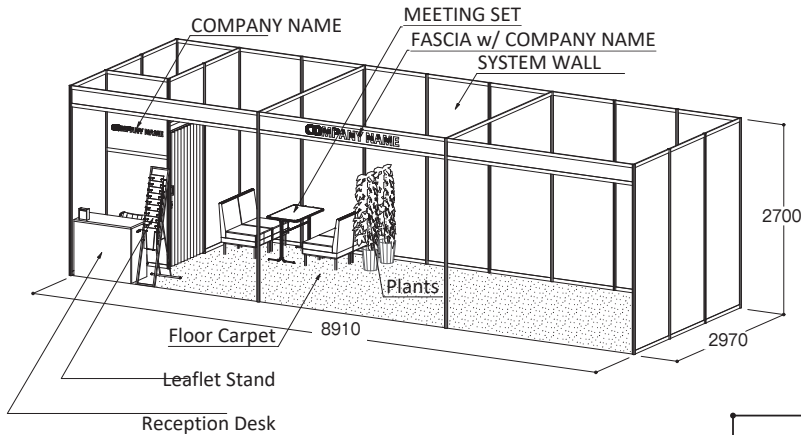

- Reception Counter W900×D500×H900 1unit
- Leaflet Stand (A4 12row) 1unit
- Table (600mm) 1unit
- Folding Chair..... 1unit

※Corner booths will not have side panels on the aisle side, but will have a parapet (without a company name sign).

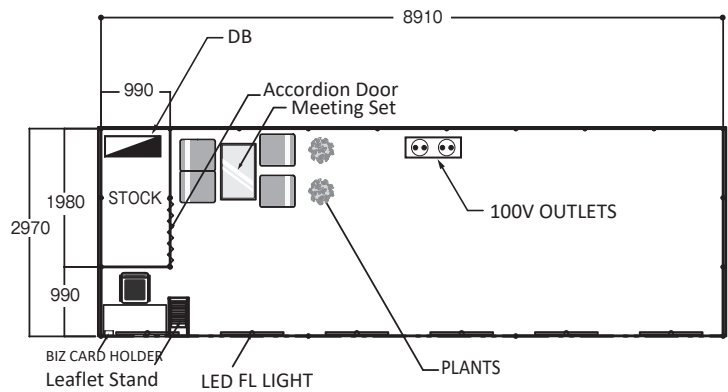

◆JPY. 326,700-(tax included.)

Facilities	1 Booth	2 Booths	3 Booths
Side and Back Partition Walls(White, 2,700mm in Height) Booth No. Plate Switch(Breaker)	Included in Standard Booth Fee (Another Application is required)		
Fascia Board	0	0	0
Company Name on the Fascia Board	0	0	0
Reception Counter(W 900 x D 450 x H 750mm)	-	1	1
Folding Chair	2	3	1
Carpeting	9ni	18ni	27ni
Outlet with 2 Plugs(Japanese Type)	1 (100V/880W)	1 (100V/760W)	1 (100V/640W)
Electrical Wiring Work and Consumption Charge for 1.0kw (100V/Single Phase)	1kW	1kW	1kW
System Display Counter (W 1,000 x D 500 x H 1,000mm)	2	-	-
Catalog Stand	1	1	1
Florecent Light	2	4	6
Name Card Holder	1	1	1
Round Table(φ600mm)	1	1	-
Wall for Stock Room	-	2	2
Lockable Acordion Door	-	1	1
Company Name at the Back of Reception	-	-	1
Meeting Set	-	-	1
Plant(Large)	-	-	2

Return this copy to the following contractor:

E-mail: expo@kogeisha.co.jp

KOGEISHA CO.,LTD.

6-17-5 Hongo Bunkyo-ku,

Tokyo1130033 Japan.

TEL:+81-3-5801-0792



- Application due: Aug. 7. 2024 -

Booth Decoration Plan Application Form

1. Numbers of Booth	<input type="checkbox"/> 1 booth (JPY157,300)	<input type="checkbox"/> 2 booths (JPY223,850)	<input type="checkbox"/> 3 booths (JPY326,700)
2. Color of Carpet <small>*Please refer to the last page of the color sample.</small>	<input type="checkbox"/> Grey <input type="checkbox"/> Blue	<input type="checkbox"/> Black <input type="checkbox"/> Green	<input type="checkbox"/> Orange <input type="checkbox"/> Red
3. Company name for showing on the Fascia Board			
4. Color of Company Name <small>*Please refer to the last page of the color sample.</small>	<input type="checkbox"/> Yellow <input type="checkbox"/> Blue	<input type="checkbox"/> Black <input type="checkbox"/> Green	<input type="checkbox"/> Red <input type="checkbox"/> Orange

Contact Person for this event: _____ Mr. Ms.

Position: _____ Department: _____

Name of exhibiting company: _____ Booth No.: _____

Address: _____

Telephone: _____ Mobile: _____

E-Mail: _____

Application of additional rental equipment:

Yes (Please refer to rental equipment catalogue for details and contact to expo@kogeisha.co.jp for any enquires.)

No

Contact person for Invoice (if different from above): _____

Address for Invoice (if different from above): _____

*Payment should be done before exhibition by bank transfer. Please refer to the invoice for the details of the bank account information.

Date: _____ Signature: _____ *Please keep a duplicate copy for your record.

<Treatment of Personal Information Clause>

Personal information received will be used for contact regarding this application form only.

Color Sample

Carpet Color

T-01
Red



T-13
Orange

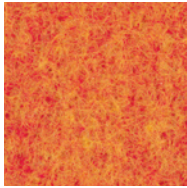

T-20
Green

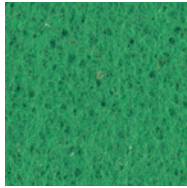

T-43
Blue



T-05
Grey

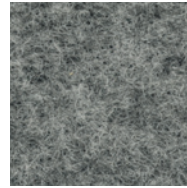

T-14
Black



Company Name Color

C-1
Red



C-2
Orange



C-3
Green



C-4
Blue



C-5
Black



C-6
Yellow

